

intersystems

Automatic Filling Systems

9575 N 109th Ave Omaha, NE 68142
402.330.1500 Fax 402.330.3350
www.intersystems.net

MODEL S-55

The model S-55 is designed to provide accurate, subsurface, liquid filling of 55 gallon drums.

Velcon subsurface fillers provide a unique programmable product level tracking system to minimize foaming, reduce drips and maintain a clean lance.

The model S-55 is made up of a robust 304 stainless steel structural construction and 316 stainless steel wetted parts. It incorporates an Allen Bradley PLC and HMI based VFC1400 control system. It has built in safety features to guarantee a safe clean and accurate filling.

Standard Features

- General purpose Non-Hazardous area electrical classification
- VFC1400 controller Hardware
 - Allen Bradley Micrologix PLC with Ethernet IP
 - Allen Bradley PanelView-Plus 400 Graphical user interface with Ethernet IP
 - 24V DC controls
- Software
 - User friendly menu driven system
 - Recipe programming and saving of all fill set points
 - Slow-Fast-Slow fill mode programming
 - Automatic Preact calculation
 - Resume capability to continue filling aborted fill cycles
 - No Drum No fill feature to prevent product spillage
 - Flow rate monitoring
 - Cycle time monitoring
 - Net weight Over/Under fill monitoring
 - System Alarm display plus historian
 - Weight indicator control, Zero, Tare, Gross/Net
 - See VFC1400 controller manual for full standard features
- Air motor and ball screw driven SUB-SURFACE FILL RAISE BY WEIGHT SYSTEM. This system will fill in subsurface mode keeping the lance at programmable position. Filling using this method eliminates foaming and keeps the lance clean.
- Two ball valve system for Slow-Fast-Slow fill modes
- Hand operated lever for Fill Start/Stop operation

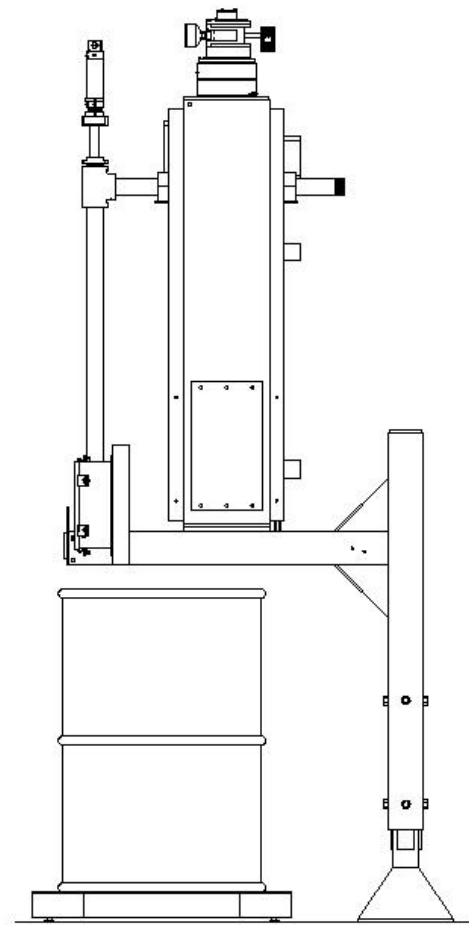

**Conveyor Optional*

Standard Construction

- 304 stainless steel structural construction
- 316 stainless steel wetted parts (Lance and pipe).
- Powder coated carbon steel control NEMA-4 enclosures
- Two piece 316 stainless steel ball valves
- Foot valve at end of lance for minimizing drips
- Gravity weighed stainless steel drip cup
- Fume collection hood with sight glass and 2" hose connection
- Teflon seals and seats
- Sealed bearings and cam followers
- Carbon steel ball screw drive system
- Carbon steel low profile scale case
 - Raised Platform
 - Sealed load cells
 - 1 part in 5,000 resolution (1,000 Lb X 0.2 LB)
 - 1,000 LB capacity

Available Options

1. Electrical area classification Options
 - Class-I Division-I area package
 - Class-I Division-II area package
2. Controller Options
 - Upgrade to PanelView-Plus 600 Color
3. Environmental area Options
 - Corrosive area package
4. Scale Base Options
 - Stainless steel scale base
 - High Capacity scale base
 - High precision scale base
5. Lance Options
 - Sanitary Lance
 - Corrosive
 - Quick Disconnect
6. Enclosure Options
 - Stainless steel
7. Structural Options
 - Dual Lance
 - Hinged wiper ring housing
8. Pneumatic Drip-pan
9. Purge through lance rod
10. Manual container grounding and monitoring
11. Automatic container grounding and monitoring
12. Overfill detection
13. Weighed container seal fume collector
14. Accessories
 - Bung tooling
 - Work platform
 - Scale mount
 - Line voltage regulator
 - Step-down transformer
 - Serial Printer
 - Spare parts
15. Conveyor
 - Extensive Conveyor Product Line available to complete your System

Sequence of Operation

- Operator programs VFC1400 for fill presets in program mode and switches to run mode
- System is ready for a fill cycle and displays “Ready To Fill”
- Operator places a container on the scale and pulls down the Start Fill lever
- Controller checks for presence of container on scale and automatically tares the container weight. If container is not detected (this is accomplished by checking the weight on the scale) the cycle is aborted automatically (Start Lever is automatically kicked up) and an error message is displayed on the PanelView plus screen.
- The lance is lowered to the bottom of the container monitoring for lance misalignment.
- System opens the foot valve and ball valves.
- System starts the fill cycle in slow fill mode until the slow fill target weight is met.
- System switches to fast fill mode until the final slow fill target weight is met.
- System switches to slow fill mode until target weight is met.
- The lance will raise by weight tracking the product level during the entire fill cycle.
- System closes the foot valve and ball valve.
- System starts raising the lance to the top position.
- System delays for settling delay time to give product to settle down.
- System recalculates Preact value.
- System kicks the Start lever up.
- System sends fill data through the serial port on the PanelView Plus.
- System is ready to fill next container.